



Low Cost Epoxy Body Conductivity Sensors For Laboratory or Light Industrial Use



Graphite or Platinum measuring surfaces available

Available with or without ATC(temperature sensor)

Use for submersion or in-line mounting

Cell constant choices of 0.1, 1.0, (10.0 - for CS200 only)

Easy-to-use fitting for in-line mounting

Our laboratory/low cost light industrial conductivity sensors feature Graphite or Platinum ring technology. Durable epoxy body construction provides a rugged and dependable sensor for portable and laboratory use.

Low cost - High Quality Sensorex conductivity probes are suitable for use with most portable conductivity meters. Add a simple mounting gland fitting, and you can use these in process applications. Mount them in-line, in a pipe "T" fitting, or submerge them into a tank.

Our general purpose models CS150 and CS150TC feature graphite measuring elements and the same durable epoxy body. For many applications, this is the lowest cost, and most reliable conductivity sensor to use, especially for process or portable applications.

Models CS200 and CS200TC feature dual platinum rings. These surfaces provide accurate, repeatable measurements. Rugged epoxy bodies make them virtually unbreakable, for long life. These are an excellent choice for your laboratory standard conductivity electrode.

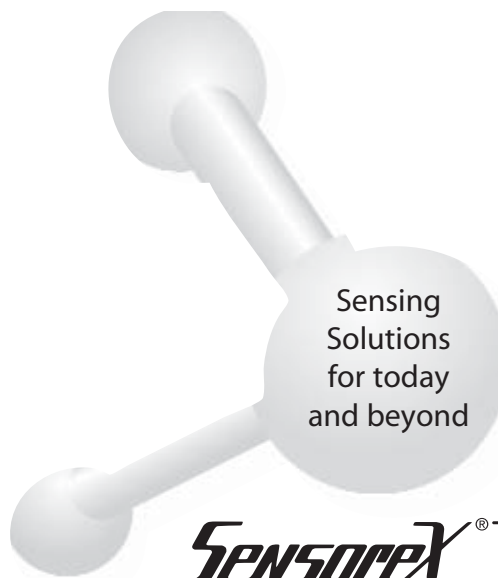

PRODUCT SPECIFICATION SHEET

Low Cost Epoxy Body Conductivity Sensors For Laboratory or Light Industrial Use

CS150, CS150TC
K=0.1

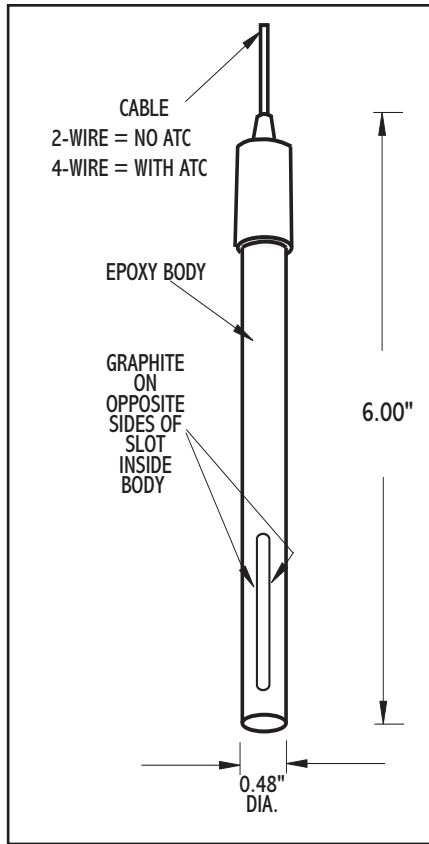

CS150, CS150TC
K=1.0

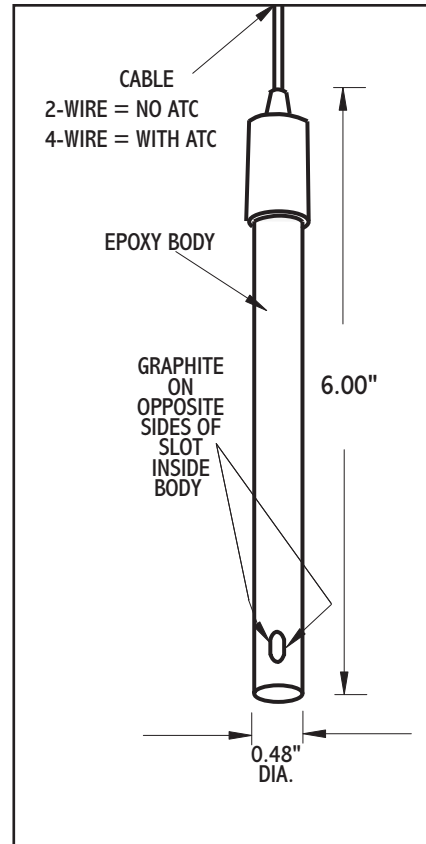

Specifications

Cell Constants Available	k=0.1, k=1.0, (k=10.0 available for CS200 and CS200TC only)
Measuring Surface	Graphite (CS150) or Platinum black coated platinum (CS200)
Body material	Epoxy
Max Temperature	0-70 Degrees C
Max Pressure	100 psig (7.5 Bar)
Temp Comp	Optional
Cable	22 AWG 2-wire or 4-wire, for "TC" type. 30 inch standard unless otherwise specified



Low Cost Epoxy Body Conductivity Sensors For Laboratory or Light Industrial Use

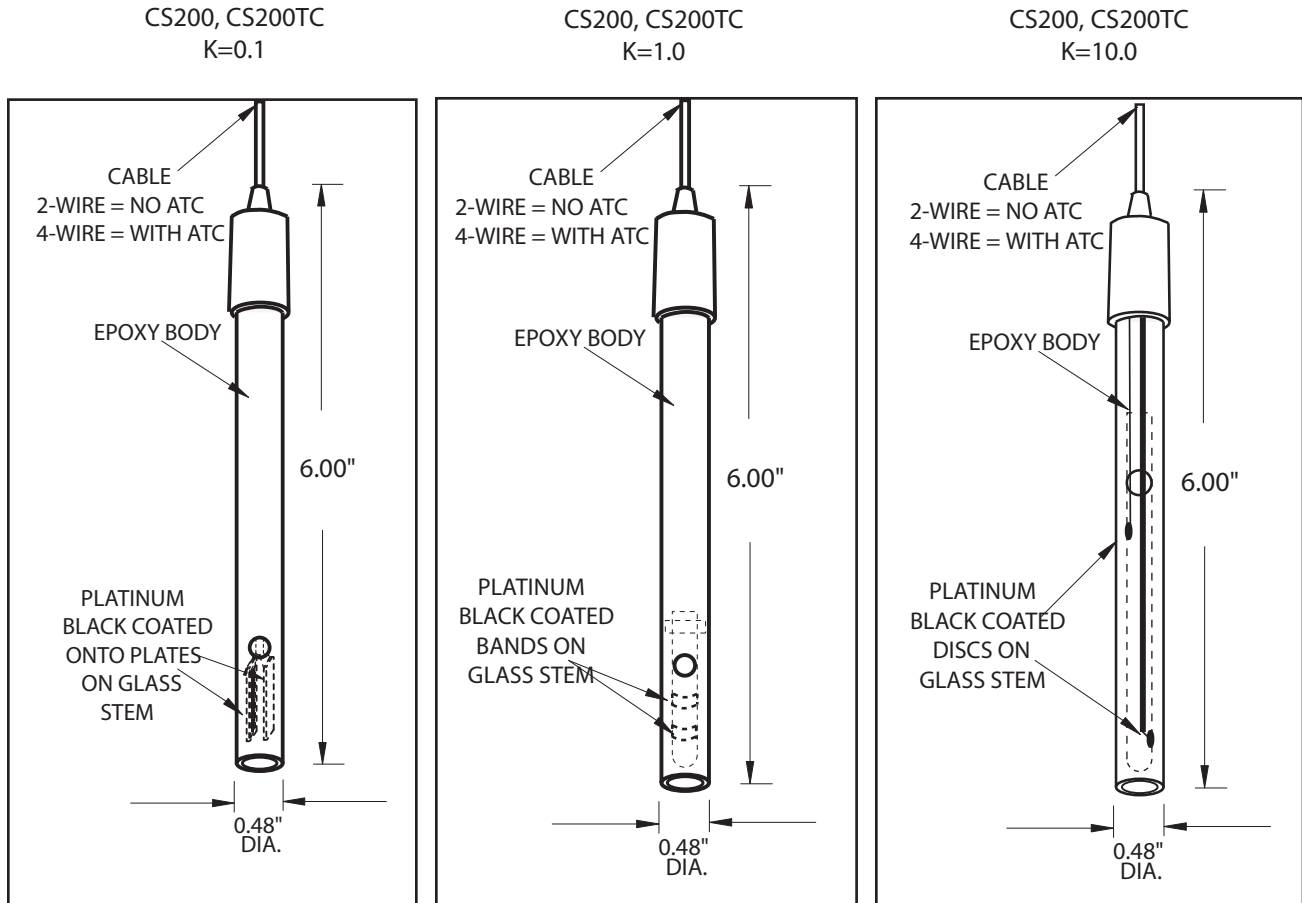

Ordering Information

Sensors

CS150	Graphite Conductivity sensor. Specify cell constant and cable length when ordering
CS150TC	Graphite Conductivity sensor with ATC. Specify cell constant, cable length and temperature sensor when ordering
CS200	Platinum Conductivity sensor. Specify cell constant and cable length when ordering
CS200TC	Platinum Conductivity sensor with ATC. Specify cell constant, cable length and temperature sensor when ordering

Notes: Sensors are supplied with 30 inch cable unless otherwise specified. Longer cable lengths and other connectors are available upon request. Temperature sensors available are 10K NTC, 30K NTC, Pt100 RTD, Pt1000RTD or contact Sensorex about custom sensors.

Additional hardware for in-line mounting

FC50P	In line mounting gland for 1/2" NPT mount
FC75P	In line mounting gland for 3/4" NPT mount

envirosensors



Distributed in Australia by
 EnviroSensors Pty Ltd, 3/271 Military Rd Cernorr NSW 2090
 ph 02 99043316 fx 02 99043319 e-mail: envirose@envirosensors.com.au